

# Quantitative VFS pesticide mitigation

Rafael Muñoz-Carpena

MITIGATION COMPLEXITY: NEED REALISTIC MODELS

1

Is not about (just) chemistry!!

**DATA**  
understand field processes and test models

**MODELS**  
quantify VFS efficiency under realistic conditions

**REGULATION**  
adoption, scenarios, implementation

COLLABORATION: ADOPTION

2

**SUSTAINABLE PRODUCTION**

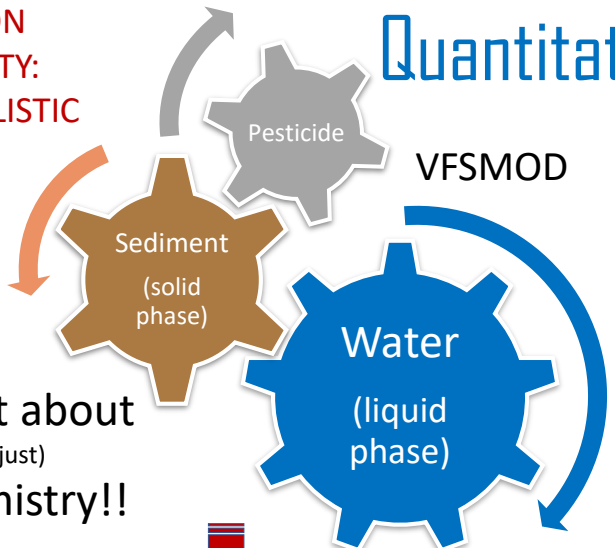

VFS MITIGATION IN EXISTING HIGHER TIER ASSESSMENT

3

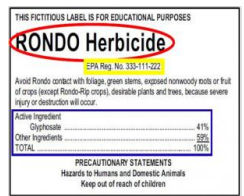
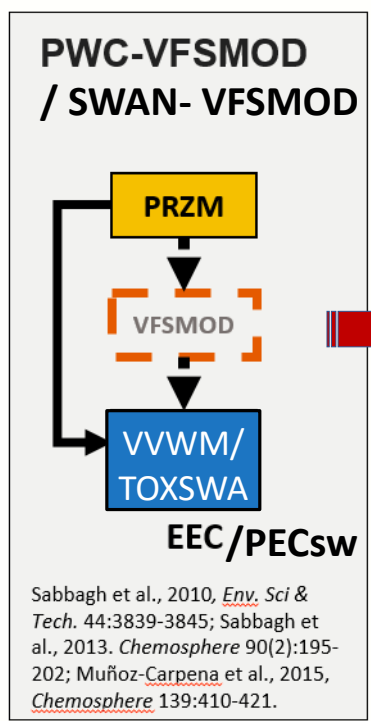
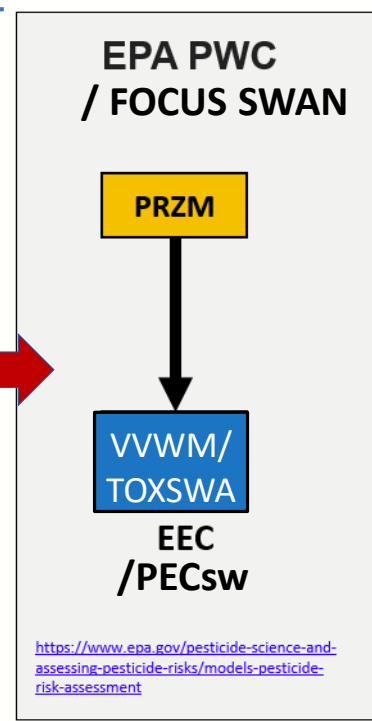

IMPLEMENTATION + maintenance

5

a) screening: VFSMOD metamodels or look-up tables

- Scenario (Ca-To/IL-corn/OR-Wheat...)
- Koc (low/medium/high)
- Degradation t1/2 (low/medium/high)
- Maintenance/channeliz. (normal/low)
- Effects (acute/chronic)
- Seasonal water table (no/yes)
- Other...

SCREEN/REFINE

4

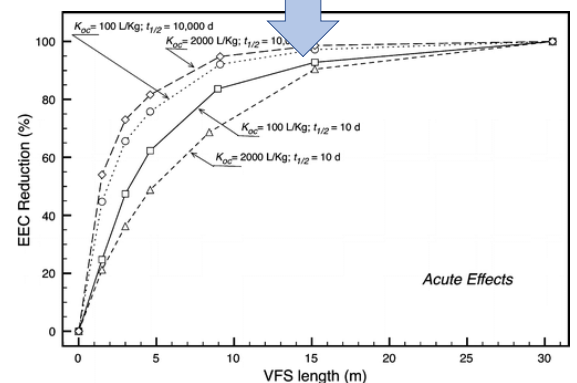

b) refinement: full VFSMOD analysis

**FOCUS Step 4 – SWAN input**

**Option 1: Reduction factors**

**Option 2: Model buffer efficiency with VFSMOD based on scenarios**